

L'humain aura-t-il une place dans l'industrie du futur ?

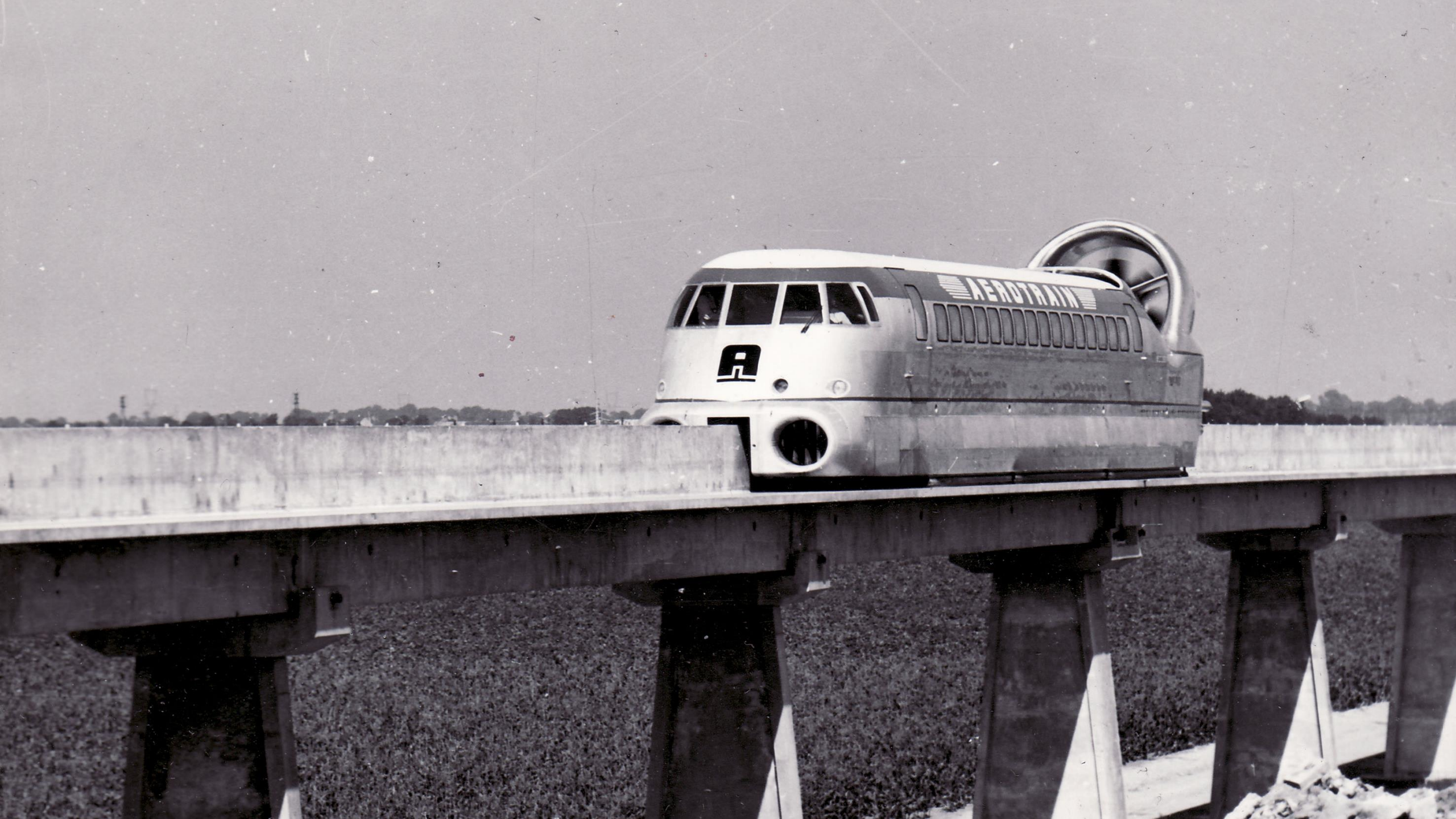

Challenges sans précédents





Challenges sans précédents



Industrie 1.0

Mécanisation
Energie vapeur
et hydraulique



Industrie 2.0

Production en masse
Electricité



Industrie 3.0

Automatisation
et Robotisation
Electronique
et systèmes IT



Industrie 4.0

Intégration de
technologies numériques
Systèmes connectés
et Cybernétique





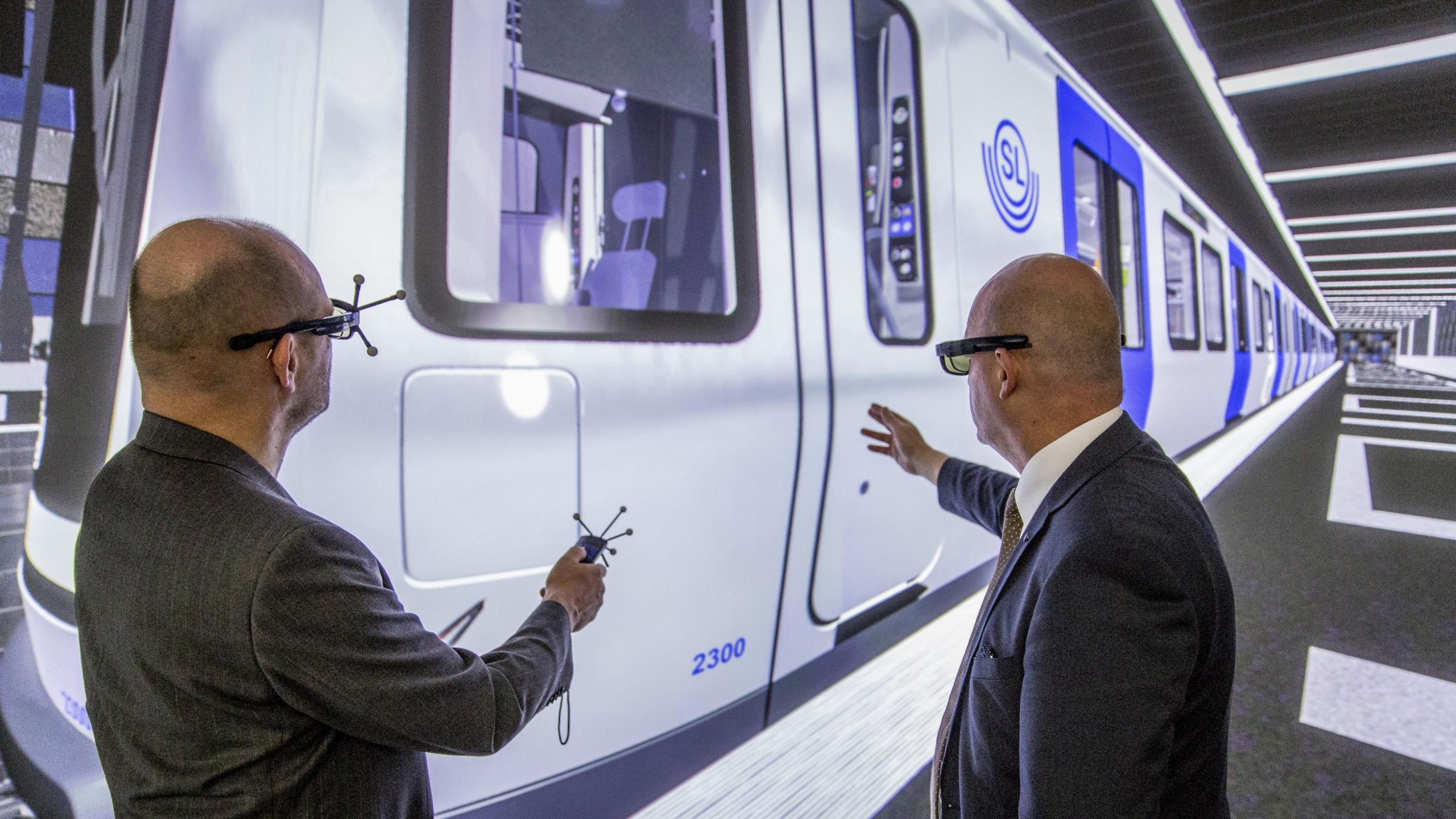

2300

SL

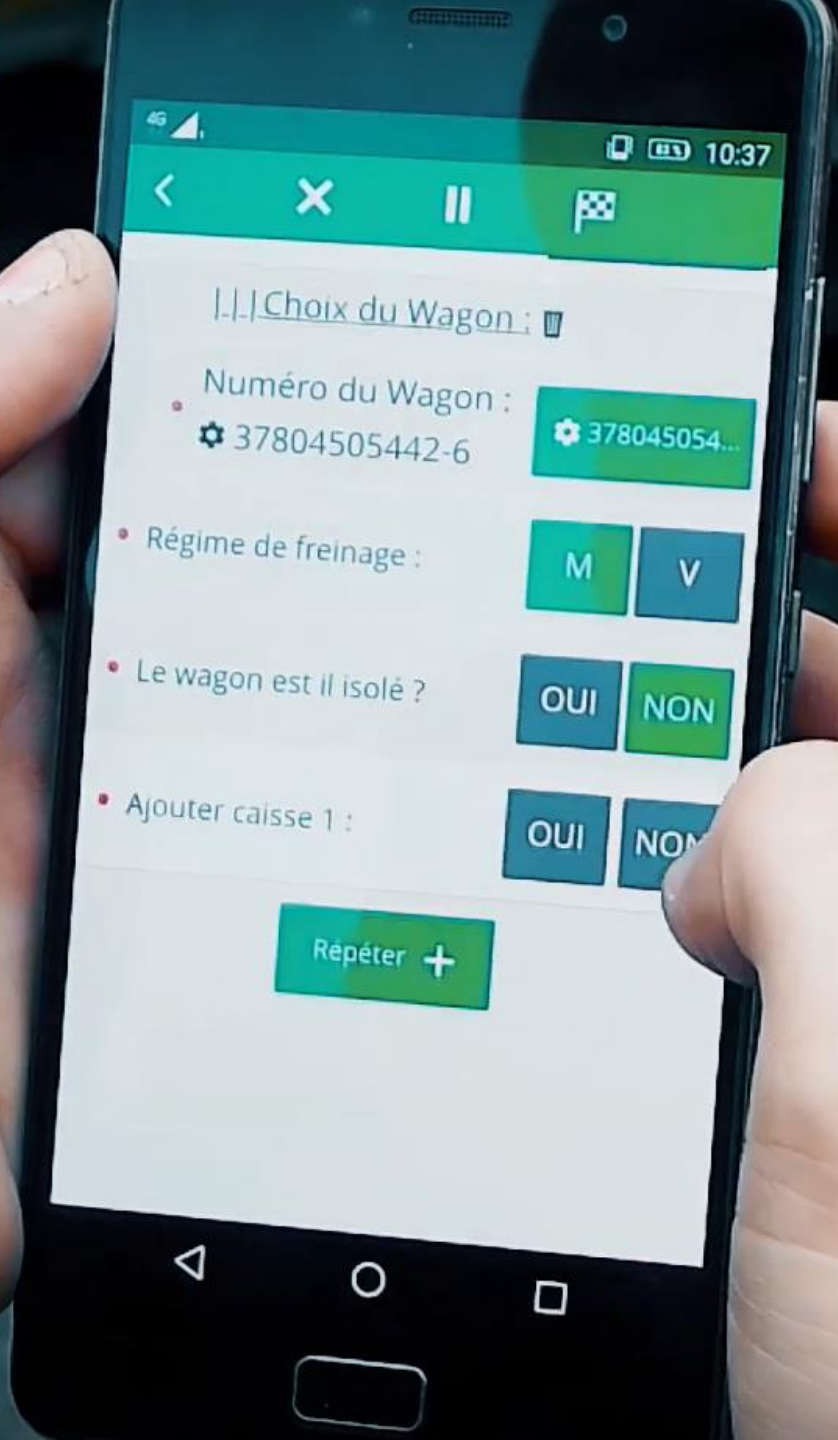

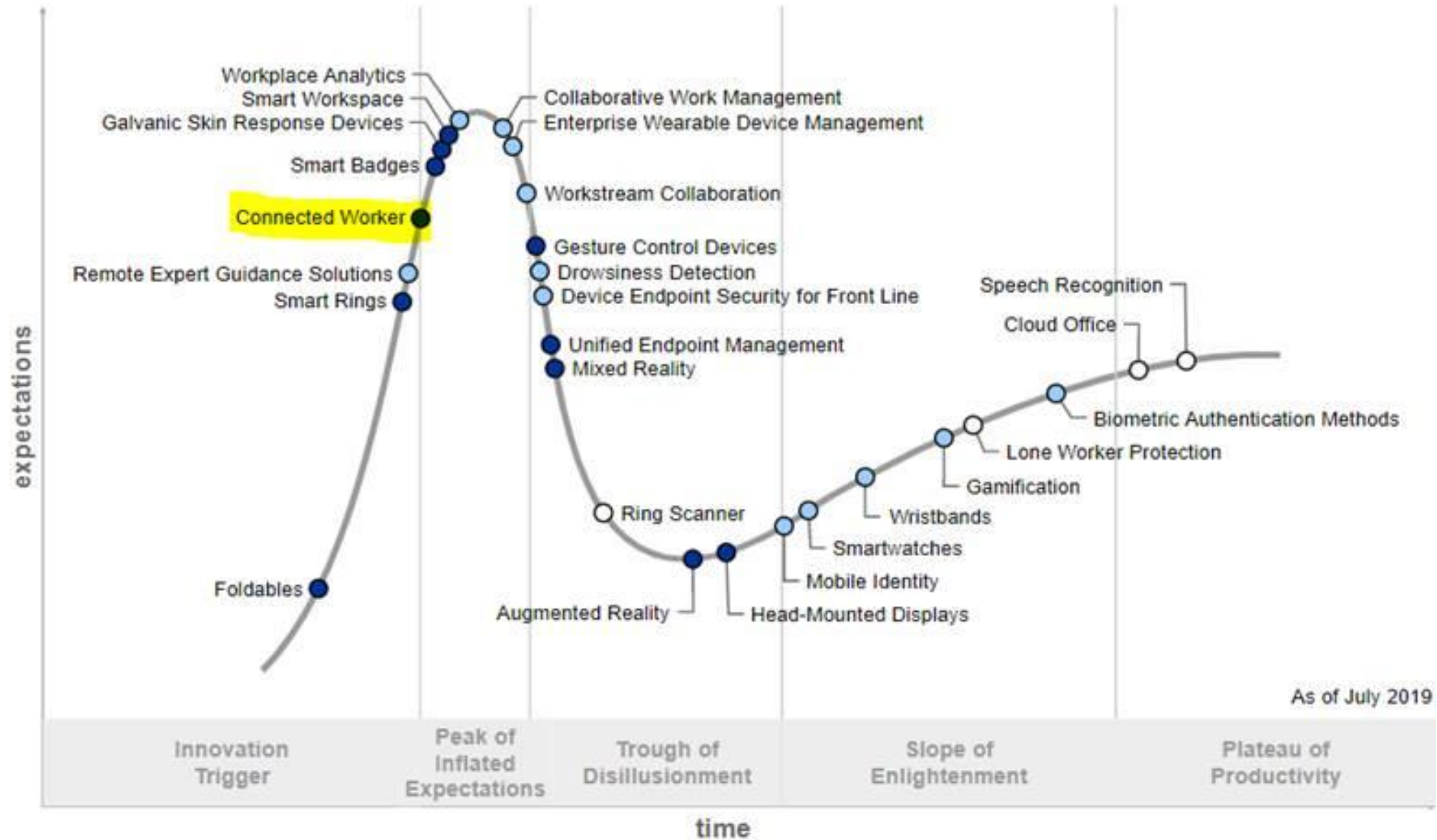

Plateau will be reached:

- less than 2 years
- 2 to 5 years
- 5 to 10 years
- ▲ more than 10 years
- ⊗ obsolete before plateau



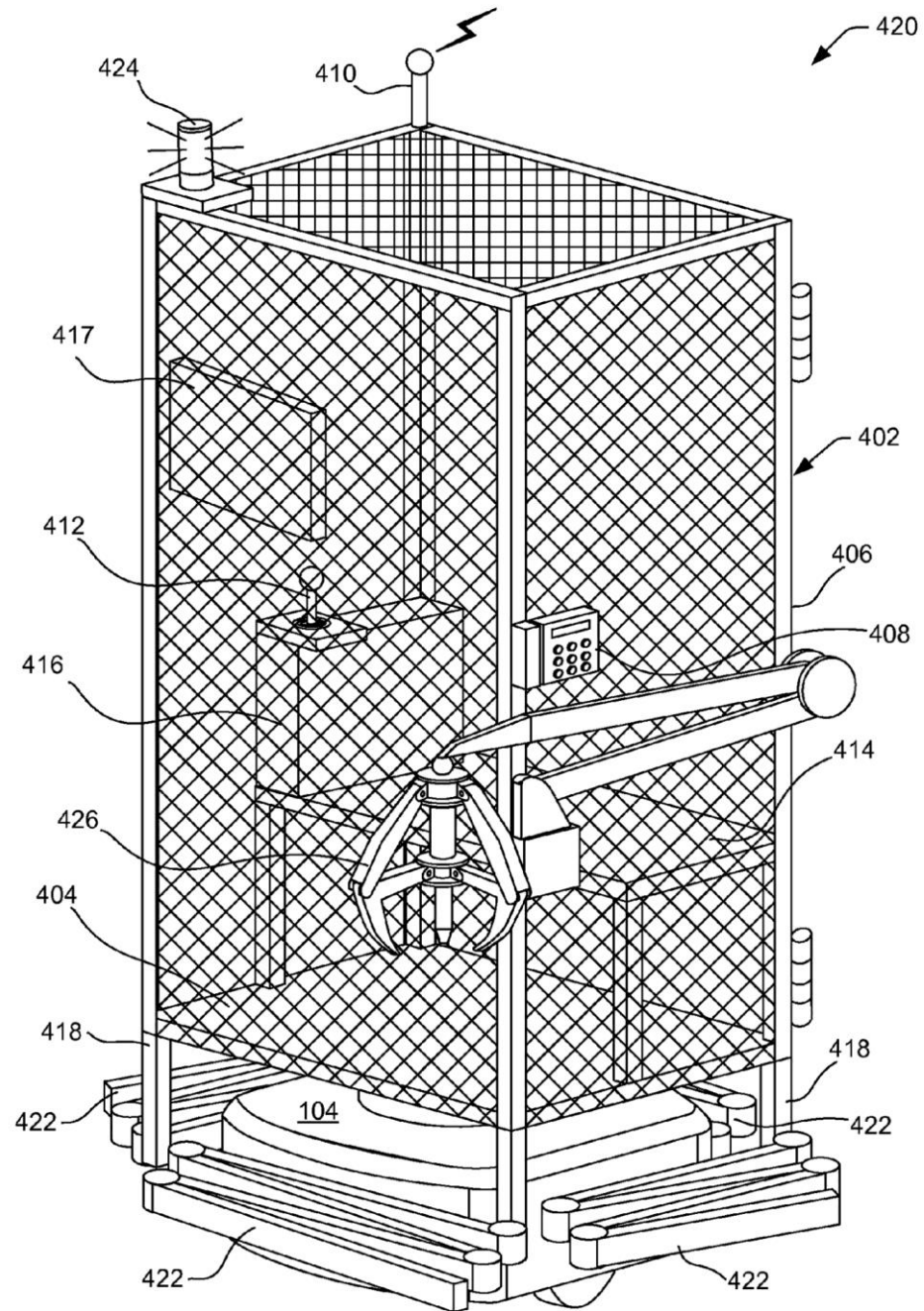











**“Le nouveau ne sort pas de l’ancien,
mais apparaît à côté de l’ancien, lui
fait concurrence jusqu’à le ruiner”**

Joseph Schumpeter

Théorie de l’évolution économique (1911)





Rexroth

designed by FeP



Consultant.e PLM

Ingénieur.e cobotique

Ingénieur.e en fabrication additive

Ingénieur.e en réalité virtuelle / augmentée

Ingénieur.e en intelligence artificielle

Responsable cybersécurité

...



Thomas DIDIER

thomas.didier@ermeo.com

+33 (0)6 32 01 65 34

www.ermeo.com

